

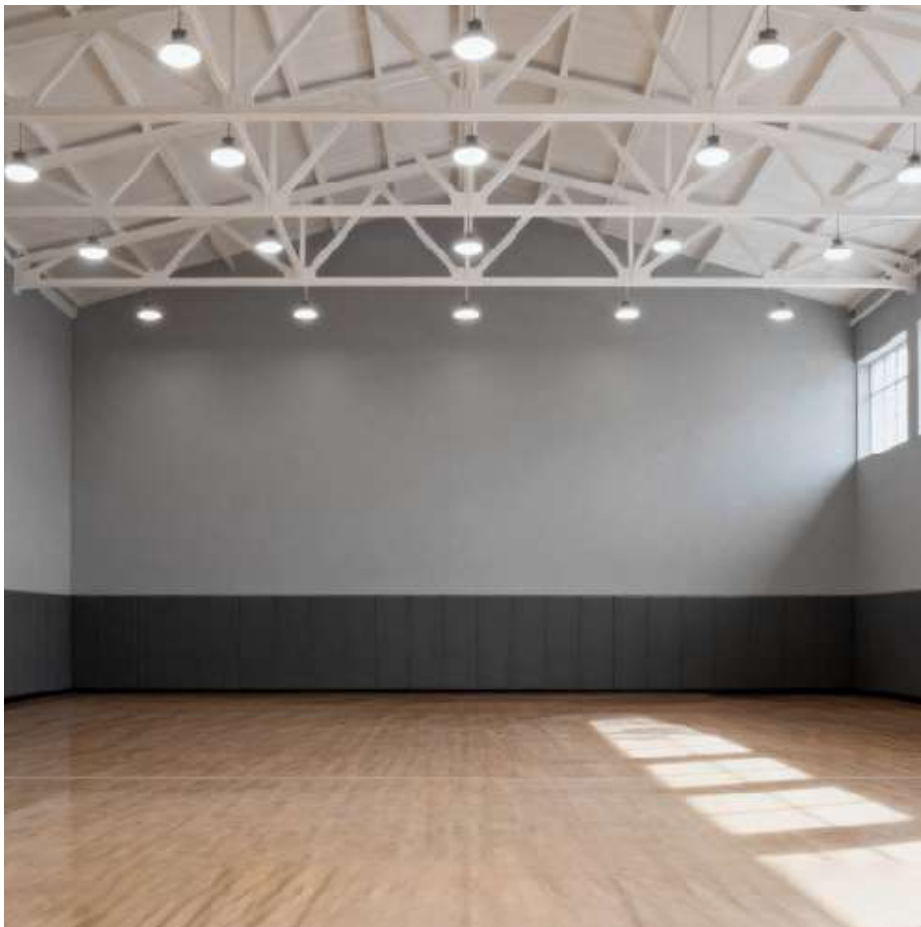

Product Name	LED Lamp for Warehouse Explosion-proof Pendant Light
Style	Industrial
Specification	Hardwired



This warehouse LED lamp is available in 50W and 100W power options.

Die-cast aluminum body and tempered glass shade with 6000K cool white light.

Explosion-proof and safe for factories, gas stations and hazardous locations.

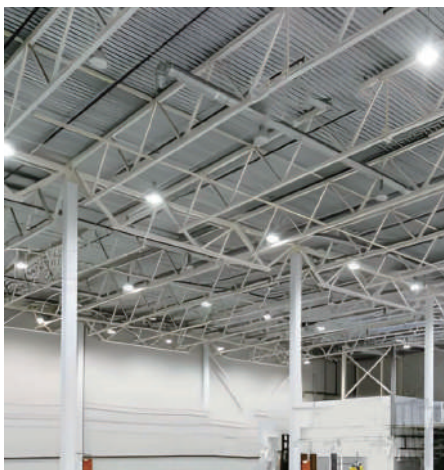

## · Basic Product Information



Product Model	HA107277-01B/ 02B
Product Type	Mini Pendants
Power Type	Hardwired
Product Color	Gray



## · Product Details

Material	Die-cast Aluminum
----------	-------------------

## · Core Specifications

Length	5.9 inches
Width	7.5 inches
Depth	7.5 inches

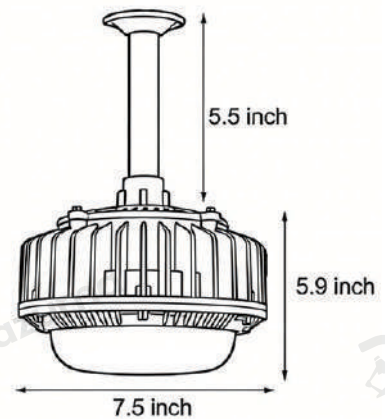

## · Basic Product Information



Product Model	HA107277-03B/ 04B
Product Type	Mini Pendants
Power Type	Hardwired
Product Color	Gray



## · Product Details

Material	Die-cast Aluminum
----------	-------------------

## · Core Specifications

Length	11.0 inches
Width	7.5 inches
Depth	7.5 inches

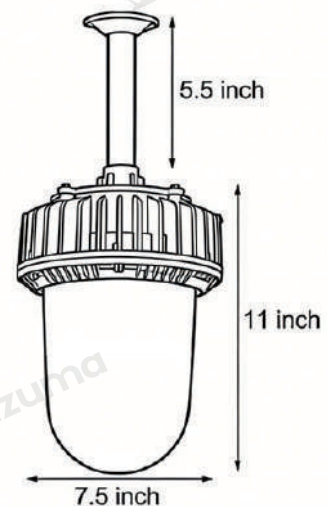



Voltage	AC100-265V
Light Source Type	LED
Light Source Included	Yes
Color Temperature	6000K
Dimmable	No
IP Rating	IP66

Hardwired

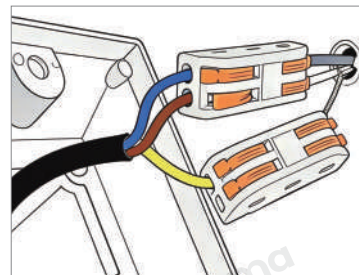

Blue: Neutral wire  
Brown: Live wire  
Yellow: Ground wire

## Core Performance Indicators



Installation Method

Ceiling Mount - Easy installation: Install with rod, cord or chain suspended from ceiling.

Application Scenarios

Indoor

Certifications

CE, ROHS, WEEE, CEC, DLC, IES

Color Temperature Adjustment

White ( 6000K )

Product Accessories

Fixture ×1, Hanger Rod ×1, Hanging Board ×1



 [www.dazuma.us](http://www.dazuma.us)

 +1 978-678-4855 (US Support)

 [hello@dazuma.us](mailto:hello@dazuma.us)

 Customer Service: Mon-Fri, 9am-6pm EST.

 Online Service Team: 120 East Hollis Street, Nashua, NH 03060